

# ARX 110C

ARTICULATED TANDEM ROLLER  
EU Stage IV / US EPA Tier 4f

## A 2-IN-1 ROLLER

The Ammann ARX 110C Combination Tandem Roller provides the benefits of vibratory and pneumatic compactors in a single machine while meeting EU Stage IV / US EPA Tier 4f emissions standards. The optional ACE<sup>force</sup> system provides a host of benefits including measurement and documentation, evaluation of material stiffness, operator guidance and documentation. The comfortable cab helps the operator stay focused throughout the shift and ultimately improves your jobsite productivity.

## COMBI BENEFITS

- Roller can be used on various layers of asphalt and at different stages of compaction
- Steel drum has vibration capability while tyres provide static compaction that creates a sealing effect
- Vibratory and pneumatic compaction with a single machine minimises fleet needs
- Amplitude and frequency are simple to adjust
- ACE<sup>force</sup> compaction measurement (absolute values) and ADS documentation system are optional

## EASY CONTROL

- Articulated steering
- Articulating oscillation joint
- 170 mm crab steering (both sides)

## EXCELLENT VISIBILITY

- Excellent visibility to drum surfaces, edges and spraying bars
- Rotating and sliding seat out from Machine contour

## OPERATOR FRIENDLY

- Spacious, comfortable and quiet cab
- Multifunctional display in steering wheel
- Tiltable and adjustable steering column
- Control switches on armrest

## EFFORTLESS MAINTENANCE

- On-board diagnostics
- Easy access to all service points
- Single-drive pump for reduced maintenance

## PRODUCTIVE OPTIONS

- Optional ACE<sup>force</sup> system measures and evaluates material stiffness, guides operator and documents the compaction process
- Chip spreader for project flexibility

## APPLICATIONS

- Medium and large jobsites
- Transport construction (motorways, railways, airfields)
- Building construction (industrial zones, harbours)

MAXIMUM RECOMMENDED COMPACTED LIFT THICKNESS AT OPTIMAL WORKING CONDITIONS

	Sand / Gravel	Mixed Soils	Silt	Clay	Stabilisation	Asphalt
ARX 110C	0.32 m (13 in)	0.22 m (9 in)	-	-	0.17 m (6.7 in)	0.13 m (5.1 in)

**AMMANN**

TECHNICAL SPECIFICATIONS  
ARX 110C ARTICULATED TANDEM ROLLER  
EU Stage IV / US EPA Tier 4f

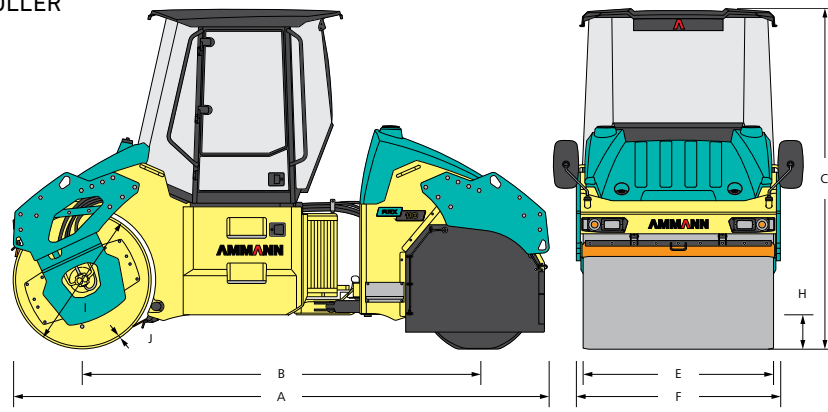

### DIMENSIONS

A	MACHINE LENGTH	4720 mm (185,8 in)
B	WHEELBASE	3500 mm (137,8 in)
C	MACHINE HEIGHT	3000 mm (118,1 in)
D	MACHINE HEIGHT (REMOVED CAB / ROPS)	–
E	DRUM WIDTH	1680 mm (66,1 in)
E	PNEU WIDTH	1628 mm (64,1 in)
F	MACHINE WIDTH	1800 mm (70,9 in)
H	GROUND CLEARANCE	300 mm (11,8 in)
I	DRUM DIAMETER	1220 mm (48,0 in)
J	DRUM SHELL THICKNESS	22 mm (0,9 in)

### MISCELLANEOUS

BRAKES OPERATING	Hydrostatic
BRAKES PARKING	Mechanical multiple-disc
BRAKES EMERGENCY	Mechanical multiple-disc
FUEL TANK CAPACITY	220 l (58,1 gal)
VOLTAGE	24 V

### WEIGHT & DRIVING CHARACTERISTICS

	ARX 110 C	ARX 110 AC
OPERATING WEIGHT	10 180 kg (22 440 lb)	10 090 kg (22 240 lb)
MAXIMUM WEIGHT	11 650 kg (25 680 lb)	11 560 kg (25 490 lb)
STAT. LIN. LOAD OF FRONT DRUM	30,7 kg/cm (171,9 lb/in)	30,2 kg/cm (169,1 lb/in)
STAT. LIN. LOAD OF REAR DRUM	29,9 kg/cm (167,4 lb/in)	–
MAX. TRANSPORT SPEED	10,5 km/h (6,5 MPH)	10,5 km/h (6,5 MPH)
MAX. WORKING SPEED	–	–
CLIMBING ABILITY WITH / WITHOUT VIBRATION	25% / 30%	25% / 30%
TURNING RADIUS INNER (EDGE)	5470 mm (215,4 in)	5470 mm (215,4 in)
CRAB MODE	170 mm (6,7 in)	170 mm (6,7 in)

### STANDARD EQUIPMENT

- CE conformity
- Open platform with ROPS canopy
- 170° rotating and sliding working station with multifunctional display
- Two stage vibration system (2 frequencies / 2 amplitudes)
- Working lights 2 front, 2 rear
- Electronic idle control
- Pneu-tire axle with emulsion sprinkling and thermal aprons

### COMPACTION FORCES

FREQUENCY I	42 Hz (2520 VPM)
FREQUENCY II	52 Hz (3120 VPM)
FREQUENCY ACE MIN. / MAX.	–
AMPLITUDE I	0,82 mm (0,032 in)
AMPLITUDE II	0,35 mm (0,014 in)
AMPLITUDE ACE MIN. / MAX.	–
CENTRIFUGAL FORCE I	120 kN
CENTRIFUGAL FORCE II	78 kN
CENTRIF. FORCE ACE MIN. / MAX.	–

### ENGINE

MANUFACTURER	Deutz TCD3,6 L4
POWER ACCORDING TO ISO 14396	74,4 kW (100 HP)
MAXIMUM TORQUE	410/1600 Nm (ft lb)/rpm
ENGINE COMPLIES WITH EMISSION REGULATIONS	EU Stage IV / US EPA Tier 4f



### OPTIONAL EQUIPMENT

- Ventilated and heated Cab
- Air Condition
- ACE<sup>force</sup> compaction measurement (absolute values) and ADS documentation system
- GPS mapping for ACE systems
- Telematics-ready
- Chip spreader Ammann
- Edge cutter