

► SPECIFICATIONS

Alldrive 3 Tonne Hi-Swivel

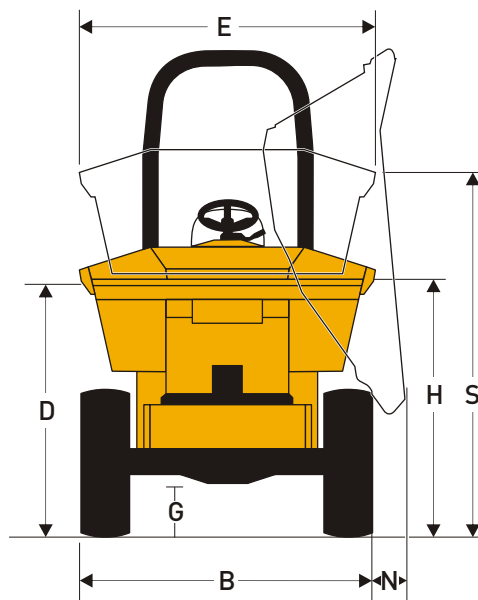
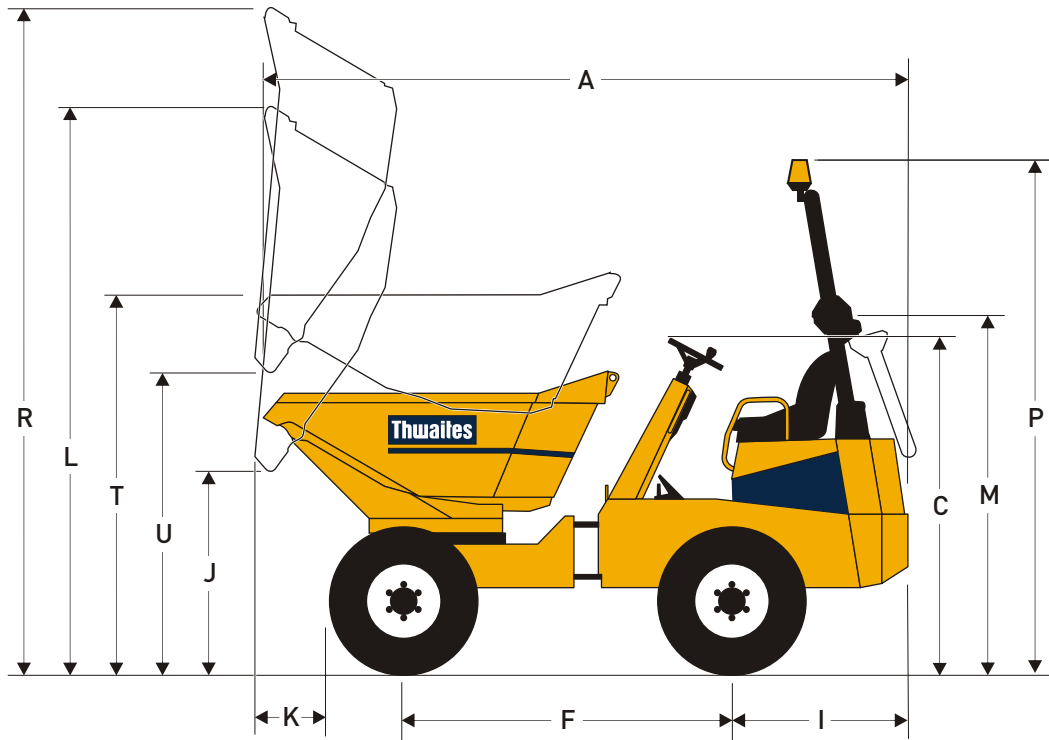

**Dimensions
(mm)**

A	3972
B	1770
C	2013
D	1600
E	1750
F	1980
G	280
H	1650
I	1130
J	1260
K	361
L	3440
M	2120
N	220
P	3140
R	4030
S	2240
T	2170
U	1850

Load-over height: Skip down – 1395 mm
Skip up – 2000 mm

SPECIFICATIONS

Alldrive 3 Tonne Hi-Swivel

Capacities	Max. safe load	3000 kg
	Heaped	1760 litres
	Struck	1300 litres
	Water	1050 litres

Engine

Yanmar 4TNV88, 33.4 kW/45 bhp (nett) at 2800 rpm, four-cylinder water-cooled direct-injection diesel. Max torque 141 Nm (104 lbf ft). Electric starting, hour meter, battery isolator switch and heavy-duty cyclonic air cleaner positioned within the lockable engine compartment.

Noise Levels

Operator's ear 84 LpA, airborne sound power level 101 LwA (to 2000/14/EC).

Transmission

Heavy-duty gearbox, three forward, one reverse, constant mesh change on the move with nickel chrome case hardened gears. Drive through 240 mm dia spring-damped heavy-duty clutch. Transfer reduction box.

Speeds	1	3.9 km/h (2.4 mph)
	2	9.0 km/h (5.6 mph)
	3	19.9 km/h (12.3 mph)
	Reverse	4.4 km/h (2.75 mph)

Tyres	295/80 x 15.3
	10 ply
	Track-grip tread

Brakes and Axles

Totally enclosed multiplate oil-immersed discs mounted on rear axle effective on all four wheels. Automatic adjustment for wear. Hand-operated parking brake. Heavy-duty axles with epicyclic reduction and fully floating halfshafts. Reduction gearbox integral with rear axle differential housing.

Kinglink Chassis

Front and rear chassis constructed from deep section folded steel plate, with three-point Kinglink giving centre articulation and oscillation for better stability and traction, coupled with tight turning circle for outstanding manoeuvrability. Remote greasing point provided for lubrication of top Kinglink articulation pin.

Skips

Hydraulically operated, 5 mm steel plate all round, fully welded, mouth and sides of skip reinforced with box sections to minimise skip damage. Variable tipping height by means of a scissor lift. Two-lever control: one to raise and lower the scissor mechanism; the other, a dual-axis lever for rotating the skip through 180° and for discharging the load.

Seating & Controls

Adjustable suspension seat, accessible from both sides. Audible warning device at key start 'on' position. Electric horn. Super-bright warning lights for all critical functions. Large pedal pads, with handbrake and hydraulic controls ready to hand.

Service Access

Lockable three-sided cover opens to provide easy access from ground level to engine service points, all located on the same side. Rear chassis panel can be hinged back on retainers. Additional service access door incorporates the battery. Moulded diesel and hydraulic tanks positioned low in the chassis side members, permitting access to the filler caps from ground level.

Electrics

Wiring harness contained within conduits and all electrical components water resistant to IP65/67 standards.

Steering & Hydraulics

Hydraulic power steering. Return line filtration for all services and large capacity suction strainer in the tank to give full circuit protection. Hydraulic test point fitted as standard.

Tank Capacities	Fuel	45 litres
	Hydraulic	45 litres

Shipping Cube	14.2 m ³ (without ROPS)
----------------------	------------------------------------

Unladen Weight	2790 kg
-----------------------	---------

Clearance Diameter	under 8 m
---------------------------	-----------

Towing Bracket	Standard
-----------------------	----------

ROPS

For the UK and other markets where it is a legal requirement, a fully approved ROPS frame fitted as standard.

Optional Extras

Folding ROPS frame. Beacon. Full road lighting equipment. UK road equipment. Anti-theft device.

Thwaites

Thwaites Ltd. Leamington Spa, Warwickshire CV32 7NQ, England
Tel +44 (0)1926 422471 Fax +44 (0)1926 337155
www.thwaitesdumpers.co.uk

Distributor



We reserve the right to change all specifications without prior notice.
Printed in England 09/2007