

AFT 200-2

TRACKED ASPHALT PAVER
COMPACT CLASS



QUALITY IN A SMALL PACKAGE

The Ammann AFT 200-2 Compact Paver is among the smallest pavers available. It is the most compact machine on the market in its class size, which helps it squeeze into tight spaces – even indoors. Its small size makes for easy transport, too. The material feeding system, reversible conveyor and separately controlled left and right augers ensure exceptional flow and ultimately provide quality. The size and intuitive controls make the paver easy to operate.

MATERIAL FEEDING

- Theoretical paving capacity up to 300 t/h
- Reversible conveyor and augers
- Left and right augers separately controlled
- Refill function for auger compartment after machine relocation

SUPERIOR SCREED TECHNOLOGY

- Standard width of 1.2–2.4 m
- Maximum width of 3.1 m with mechanical extensions
- Minimum width of 0.3 m with reduction shoes
- Gas or electric heating

OPERATOR STATION

- Good sight lines
- One-man paving option
- Low noise levels
- Back rest for safety

UNDERCARRIAGE & DRIVETRAIN

- Powered by 49 kW engine
- Compact for easy transport
- Narrow dimensions for tight jobsites
- Ability to be used indoor

SERVICEABILITY

- Easy access
- All-in-one box kits available
- Easy replacement of dashboard toggle switches

APPLICATIONS

- Footpaths
- Cycling tracks
- Trenches
- Narrow roads
- Parking lots
- Property entrances

AMMANN

TECHNICAL SPECIFICATIONS
AFT 200-2
TRACKED ASPHALT PAVER
COMPACT CLASS

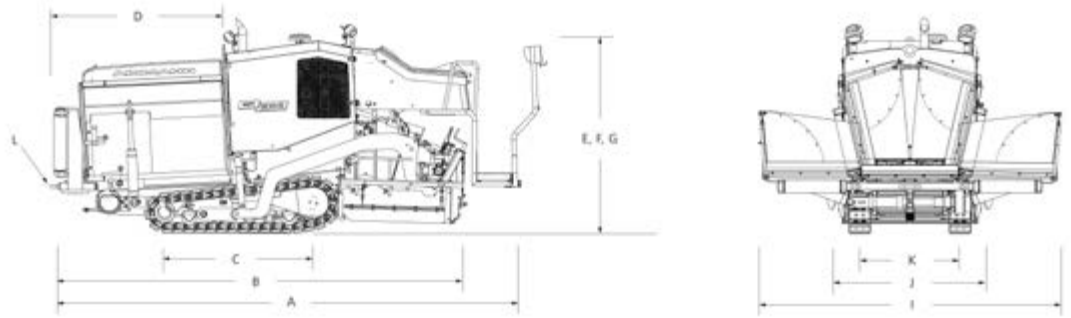

WEIGHT & DIMENSIONS

WEIGHT (INCLUDING STANDARD SCREED)	5900 kg
A MACHINE LENGTH	4360 mm
B TRANSPORT LENGTH	3880 mm
C TRACK LENGTH	1390 mm
D HOPPER LENGTH	1310 mm
E MACHINE HEIGHT	1900 mm
F TRANSPORT HEIGHT	1900 mm
G HEIGHT	1900 mm
H MATERIAL LOADING HEIGHT	570 mm
I MACHINE, OPEN HOPPERS WIDTH	2830 mm
J TRANSPORT WIDTH	1200 mm
K TRACK GAUGE WIDTH	940 mm
L MAX. APPROACH ANGLE	15.5° (front) / 10° (back)

CAPACITY & PERFORMANCE

PLACEMENT THICKNESS (MAX.)	200 mm
THEORETICAL PAVING CAPACITY	300 t/h
PAVING SPEED (MAX.)	27 m/min
TRANSPORT SPEED (MAX.)	3.3 km/h

CRAWLER

CRAWLER LENGTH (AXLE TRACK)	1390 mm
CRAWLER WIDTH (PADS)	205 mm
FINAL DRIVE	Direct drive over transmission

SCREED OPTIONS

	SV 2400 G	SV 2400 E
BASIC WIDTH	1.20 m	1.20 m
HYDRAULICAL EXTENDED WIDTH	2.40 m	2.40 m
MAX. WORKING WIDTH	3.10 m	3.10 m
HEATING SYSTEM	Gas (LPG)	Electric
SCREED TYPE	Vibration screed	Vibration screed



MATERIAL FEEDING SYSTEM

HOPPER CAPACITY	5 t
HOPPER DUMPING HEIGHT CENTER (W. HOPPER FLAP)	570 mm
HOPPER WIDTH, INTERNAL	2830 mm
CONVEYOR TYPE	Split drive conveyor with center cover
CONVEYOR WIDTH	620 mm
CONVEYOR CONTROL	Automatic with limit switches
AUGER DIAMETER	320 mm
AUGER CONTROL	Automatic with ultrasonic sensors
AUGER HEIGHT ADJUSTMENT	150 mm (mechanical)

ENGINE

ENGINE MODEL	Deutz TD2.9 L4
RATED POWER @ 2200 RPM	49 kW
EMISSIONS	EU 3A / 3B (T3 / T4f)
ELECTRICAL SYSTEM	24 V
FUEL TANK CAPACITY	85 l

OPERATOR STATION

OPERATOR CONSOLE	Conventional control
DASHBOARD	Conventional control
PLATFORM	With back rest for operator safety
ROOF	No canopy